

How to Save Acetonitrile – Part 1

As people worldwide became aware of environmental problems, decrease of burden on the environment has been desired in recent years.

In HPLC analysis, reduction in usage of organic solvent for mobile phase, such as acetonitrile and methanol, has been

promoted. The typical approach is to use columns with small inner diameters with low flow rate.

In this note, a convenient apparatus for recycling mobile phase in isocratic elution is described.

(T.Tamura)

Solvent Recycler, SR671

This apparatus should be installed downstream of detectors in HPLC systems and enables us to reuse the mobile phase using a solenoid valve. The eluent from the detector is sent back to the bottle of mobile phase while

no peak is detected. When peaks are detected, the valve is activated, and the eluent of the peak fraction flows to waste line. As a result, actual solvent consumption can be reduced.

A diagram of an HPLC system with an SR671

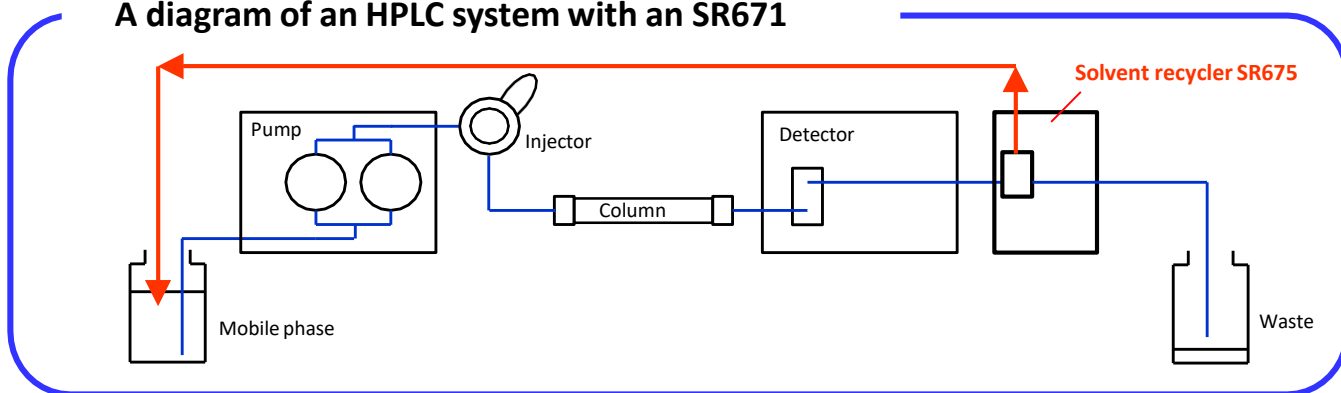

Auto mode

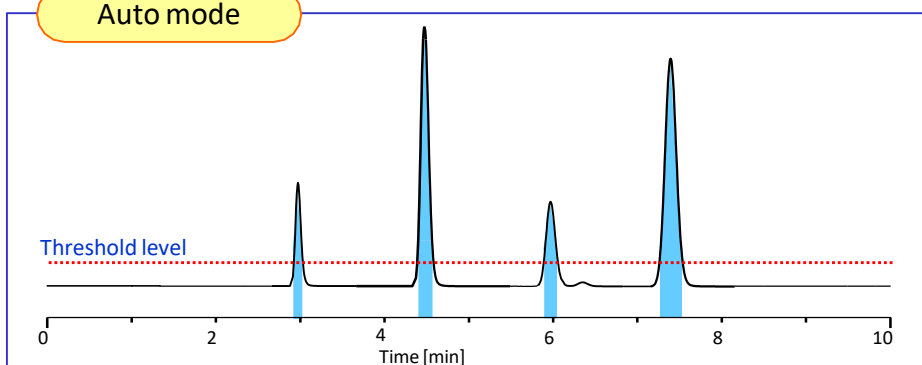

In auto mode, peaks were automatically detected by setting a threshold level. Only when the signal from the detector exceeds the threshold (Blue area (■)), the eluent is sent to waste line.

Time Mode

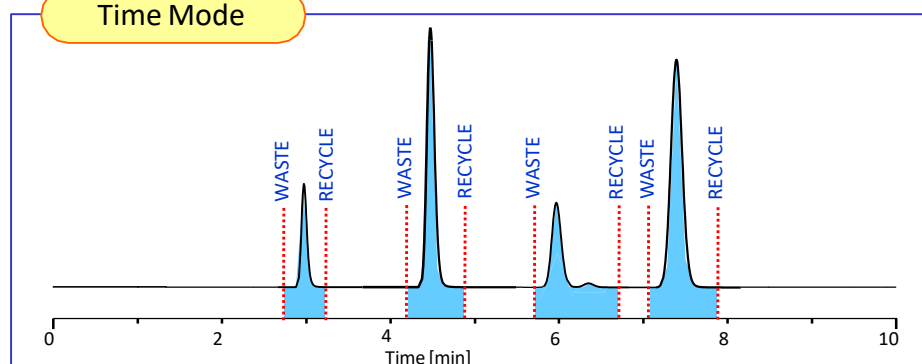

In time mode, the valve is operated according to a preset time program. The valve is switched repeatedly, and the eluent in arbitrary times (■) is sent to waste.

* Manual mode, in which the valve is controlled by manual keyboard operation, and remote mode, in which the valve was switched by an external contact signal, are also available.

Specifications

Modes	AUTO, TIME, REMOTE, MANUAL
Input	Signal from detector (10 mV or 1 V), remote start signal
Valve	3-way solenoid valve (wetted material: PTFE)
Dimensions / weight	120 (W) x 260 (D) x 140 (H) mm (except for a solenoid valve) / 2.5 kg
Power requirements	AC 100 - 240 V 50 / 60 Hz
Cat. No.	6001-67100



GL Sciences disclaims any and all responsibility for any injury or damage which may be caused by this data directly or indirectly. We reserve the right to amend this information or data at any time and without any prior announcement.

GL Sciences, Inc. Japan

22-1 Nishishinjuku 6-Chome
Shinjuku-ku, Tokyo,
163-1130, Japan
Phone: +81-3-5323-6620
Fax: +81-3-5323-6621
Email: world@gls.co.jp
Web: www.glsciences.com

GL Sciences B.V.

De Sleutel 9
5652 AS Eindhoven
The Netherlands
Phone: +31 (0)40 254 95 31
Email: info@glscienc.es.eu
Web: www.glsciences.eu

GL Sciences (ShangHai) Ltd.

Tower B, Room 2003,
Far East International Plaza,
NO,317 Xianxia Road,
Changning District.
Shanghai, China P.C. 200032
Phone: +86 (0)21-6278-2272
Email: contact@glscienc.es.com.cn
Web: www.glsciences.com.cn

GL Sciences, Inc. USA

4733 Torrance Blvd. Suite 255
Torrance, CA 90503
Phone: 310-265-4424
Fax: 310-265-4425
Email: info@glscienc.esinc.com
Web: www.glsciencesinc.com

International Distributors

Visit our Website at:

<https://www.glsciences.com/company/distributor.html>